

Three-phase capacitors: 240 V, 50 Hz, IP 20, MKP

Typ Type	Výkon Power Q_N [kvar]	Kapacita Capacitance C_N [μ F]	Proud Current I_N [A]	Váha Weight [kg]	Rozměry Dimensions $\varnothing D \times H$ [mm]
CSADG 1-0,24/5	5	3 x 92,2	3 x 12,0	1,1	85 x 245
CSADG 1-0,24/7,5	7,5	3 x 138	3 x 18,0	1,2	
CSADG 1-0,24/10	10	3 x 184	3 x 24,1	1,8	110 x 245
CSADG 1-0,24/12,5	12,5	3 x 230	3 x 30,1	2,1	

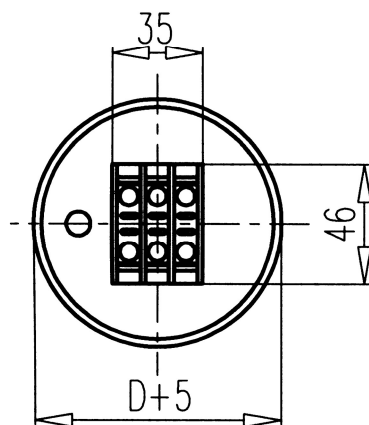
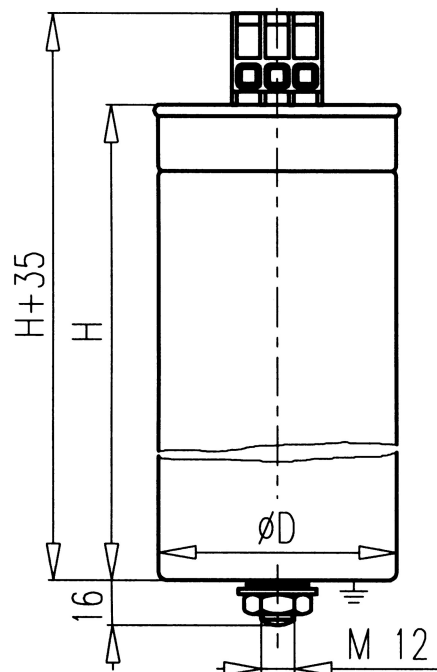

Technická data/ Technical data:

Teplotní kategorie/ Temperature category: -40/D

Vybíjecí odpory/ Discharge resistors: 50 V/ 1 min

Izolační hladina/ Insulation level: 3 / - kV

Konstrukce/ Design: SH - suché provedení N_2 / SH - dry type N_2 , non PCB

Normal Standard: IEC 60831/96

Kreslil	Michalovičová	Dne	4.10.2007	Změna	
Schválil	Falta Vladimír	Dne	26.11.2009		



Název:

TECHNICAL SPECIFICATION
240 V, 50 Hz, 3-F, IP20

3J 2151 A